

Fan Specifications

Model EVOAX/150EC

EVOAQ
for your Home & Health



MODEL	EVOAX/150EC
Fan Construction	ABS
Voltage	230 VAC
Frequency	50 Hz
Peak Current (A)	0.012 ~ 0.123
Fan Speed (RPM)	500 ~ 3300
Air Flow (m³/hr)	56 ~ 399
Air Flow (L/s)	16 ~ 110
Pressure (Pa)	240
Max Power (W)	20
Sound (dB(A) Av)	31
Max Operating Temp (°C)	60
IP Rating	IP44
Climate Class	T
Compliance	AS/NZS 60355.2.80 T

ENERGY EFFICIENCY

EVOAQ **A+** EVOAX/150EC **A+**

31
dB

399
m³/hr

Model	Voltage (V/Hz)	Power (W)	Speed (RPM)	Airflow (m ³ /hr)
EVOAX/150EC	230/50	2 ~ 20	500 ~ 3300	56 ~ 399

Specific Fan Power (SFP)
0.151 Watts per L/s

Fan Features

- High-flow and high-pressure fan
- EC Single Phase DC motor
- Re-engineered for New Zealand
- Bearing life rated for 50000 hours
- Constant variable airflow
- Low voltage (0-10V) PWM control
- Internal thermal management control

Performance Curve

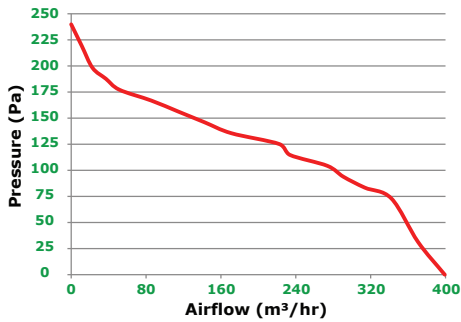

Energy Curve

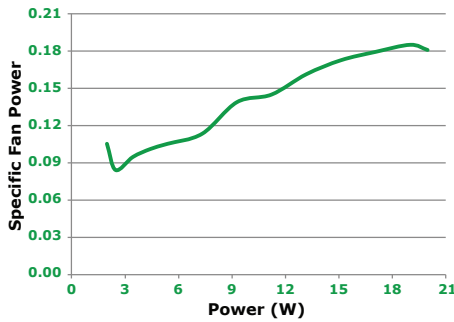

Flow rates RPM

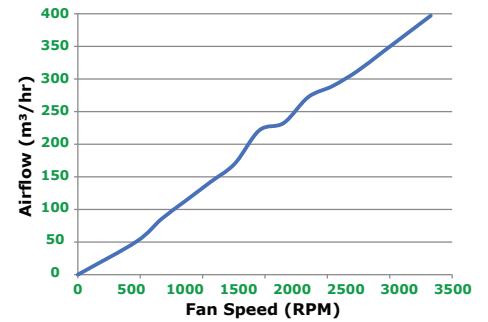

Sound Performance Parameters

	dBa @ 3m	63 Hz	125 Hz	250 Hz	500 Hz	1 kHz	2 kHz	4 kHz	8 kHz	Total SPL
500 RPM	21.9	38	37	39	37	38	35	30	30	45.4
1500 RPM	36.2	47	46	54	55	53	49	32	38	59.7
3000 RPM	39.8	49	49	57	59	57	52	47	42	63.3

Fan Dimensions

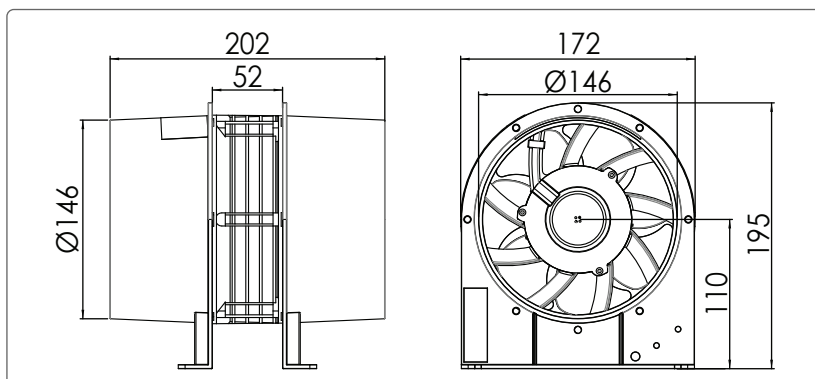

For more information, visit www.evoaq.co.nz